

ADVANCED MOTION ANALYSIS

image TEMA PRO

Contact

Image Systems Nordic AB

Snickaregatan 40, 582 26

Linköping, Sweden

sales@imagesystems.se

Note

For TEMA T2020
and more recent versions

TEMA Pro is the market-leading software suite for advanced Motion Analysis tests in research and industry.

Thanks to its high accuracy, modular structure, calculation speed and intuitive user interface - TEMA Pro is used by professionals across the globe in a wide range of applications from drop testing smart phones to improving sport performances or even optimizing processes in the automotive and aeronautical industry through the tracking of trajectories.

TEMA Pro has a wide library of tracking algorithms included in its default package which allows to track

almost any kind of objects in any situation.

In addition to TEMA Classic's set of algorithms, Outline and Digital Image Correlation are part of the default package. The algorithms are based on pattern recognition and/or levels of grey and allow tracking with sub-pixel accuracy.

It is also possible to generate an exportable viewer to be read on any machine with or without TEMA installation in order to interact with diagrams and data. This makes TEMA Pro the most advanced tracking suite on the market.

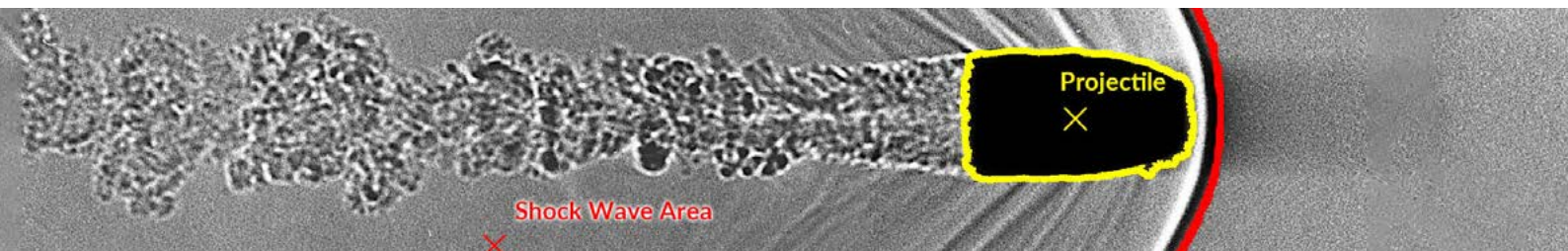

Outline Tracker in Projectile Schlieren Analysis

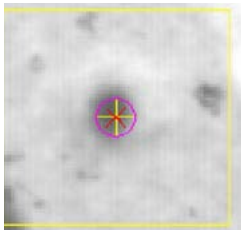

CORRELATION

Looks in each successive image for the area that correlates best with the pattern defined in the first image.

This method is applicable to most cases, as it doesn't require a marker.

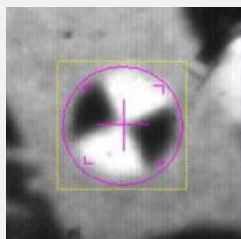

QUADRANT

Automatically locks to the centre of the quadrant target and is invariant to rotation, scaling and change in light conditions. It provides the position of the centre of the quadrant target as well as its angle in regards to a given orientation.

Quadrant targets are recommended for applications with high demand on accuracy and automation.



VIRTUAL POINTS

The Virtual algorithm triangulates the position of a point (visible or masked in the sequence) by using the tracked position of at least 3 other points from the same rigid object and which are visible in the sequence. The points must be part of the same group to apply the virtual algorithm.

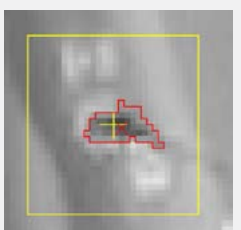

CENTRE OF GRAVITY

Centre of gravity of a closed contour or a contrasted marker/object with the background. The detection is based on level of grays in the image and threshold can be defined automatically for dark or bright objects or manually using sliders on a 0-255 colour scale. The centre of gravity algorithm is not sensitive to scaling.

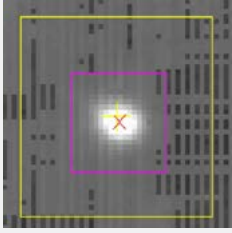

CIRCULAR SYMMETRY

Finds the symmetry centre of the image within the search area.

It is applicable to concentric circles, spokes on a bicycle wheel or combinations thereof.

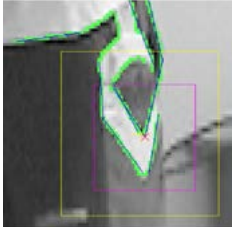

INTERSECTION

Tracks intersection points (corners) on any object shape.

The algorithm detects the intersection of contrasted edges by extrapolating straight lines along those edges and fills gaps if necessary.

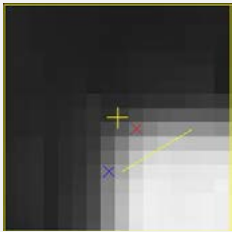

CORNER CONTOUR

The Corner Contour Tracker can detect edges and find corners along these edges.

One corner will be selected as the track point



MOUSE TRACKER

In the case any form of automatic tracking would fail due to poor quality of images, the operator can manually track the object of interest in a sequence using a mouse pointer.

The playback speed can be adjusted to help the process.

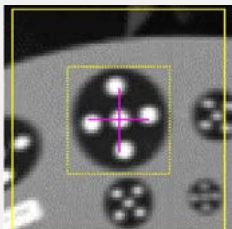

MXT (Optional)

Finds the symmetry center of the image within the search area.

The user can set the target to 1+4 and 1+5 MXT target tracking.

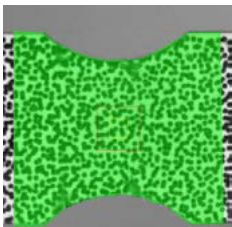

DIC

Digital Image Correlation (DIC) allows surface deformation and strain analyses by tracking the movement and deformation of a speckle pattern painted on the object of interest. The pattern must obey some guidelines for good analysis.

* Stereo DIC is available with 3D module (optional) and using 2 or more cameras.

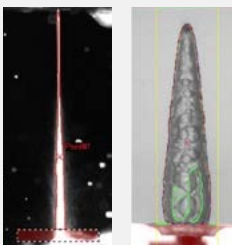

OUTLINE

Captures the evolution of the contour of an object through 3 different algorithms,

- Basic outline for simple cases with nice contrasted contour of the object with the background.
- Advanced outline for complex objects with the need of dynamic thresholding for shadows and reflections on the inside of the object of interest disturbing the detection.
- Outline+ algorithm with extreme background suppression and image processing functions with configurable parameters for tracking the contour of an object in harsh conditions with low contrast.



Checked Lens Calibboard

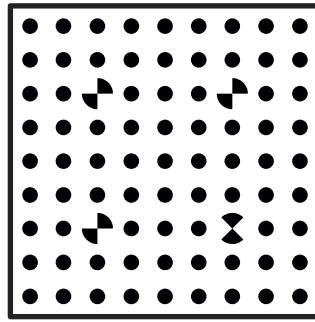

Smart Lens Calibboard

Available in TEMA PRO for automatic lens calibration

The Planar Target Calibration Board consists of a rigid two dimensional flat board with evenly distributed markers.

The workflow is rather simple:

1. Capture a sequence of images with different orientations of the board;
2. Identify the 4 quadrant markers on the checker board in each image or track them in the case of a continuous sequence
3. Inspect results of the lens calibration. A distortion table is available in addition to the summary of all calibrated parameters with their accuracy.

PARAMETERS

Typical parameters that can be calibrated

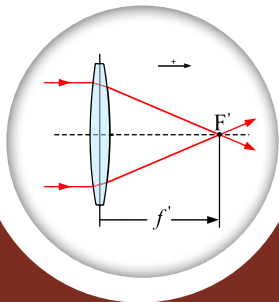

Focal Length

The focal length is measured in pixels.
As the focal length varies with focus settings, the calculated value may differ from the nominal value specified by the lens manufacturer.

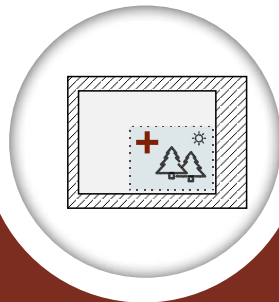

Principal Point

The principal point represents the point of the image where the distortion is centered, or possibly zero and corresponds to the optical axis of the camera.
In the case the resolution was cropped to increase frame rate, the principal point will still be close to the center of the sensor.

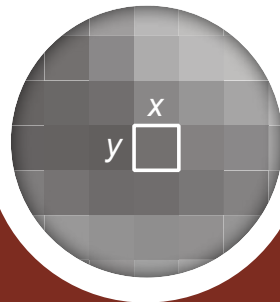

Aspect Ratio

Pixel Aspect Ratio (PAR). The "squareness" of pixels, normally "1:1".
In certain older videos, the image is stretched to fit the screen. A rendering of this format can result in a non-square-pixel.

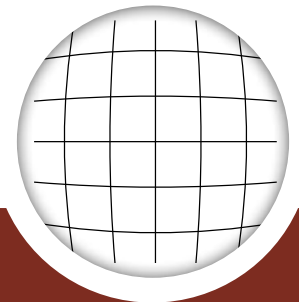

Lens Distortion

Although distortion can be irregular or follow many patterns, the most commonly encountered distortions are radially symmetric.
Depending on lens quality and focal length, distortion may be significant.



Calibration Status			
Calibration Successful			
Calibrated Parameters			
Parameter	Value	Accuracy (std dev)	Unit
f	23271.13	24.44	pixels
f (length units)	113.56	0.11927	mm
Principal pointx	3212.00	37.13	pixels
Principal pointy	2440.80	30.87	pixels
Aspect ratio	0.99955	0.00014160	
R0	23140.00	0.00	pixels
A1	-0.19664	0.062301	
A2	-1.7674	8.2740	
A3	83.000	323.30	
B1	0.0024151	0.00027921	
B2	-0.0031458	0.00029947	
Residuals			
Mean Residual =	1.13 pixels	Max Residual =	5.92 pixels
Standard Deviation =	0.80 pixels		
Distortion Table			

INSPECT RESULTS

- Residuals for Each Frame
- Calculated Focal Length
- Impact of Lens Distortion
- Coefficient for Radial Distortion Correction
- Point with Max Residual



AUTOMATED & ACCURATE

Simultaneously calibrate the orientation, distortion and focal length of all cameras on the scene by tracking a single sequence of a calibrated illuminated tool



Complete Solution

- Calibrated carbon fiber tube
- 3D printed LED bulbs
- Battery power
- Allen key & screw assembly
- Portable case
- Flexible measurement volumes from 1m×1m×1m to 10m×10m×3m



Calibration Procedure

1. Position cameras
 - 30°~150° acceptable
 - 90° optimal
2. Record calibration images
 - Maximize contrast
 - Avoid motion blur
 - Regular room lighting
3. Record test images
4. Analyze test 3D results



Key Benefits

- Fast and automated with accuracy report
- Unlimited camera numbers and brands
- Calibrate all cameras simultaneously with
 - Focal Length
 - Lens Distortion
 - Camera Orientation (x, y, z, roll, pitch, yaw)

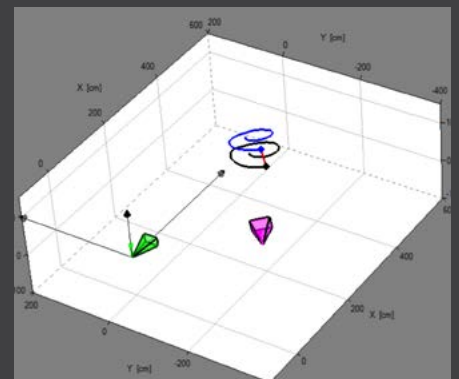
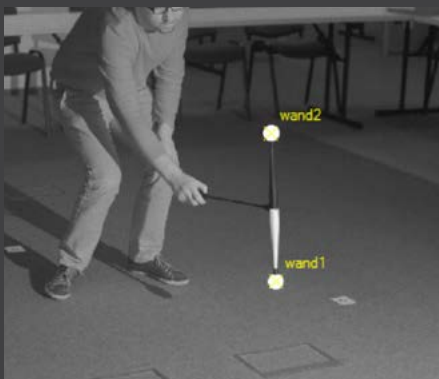

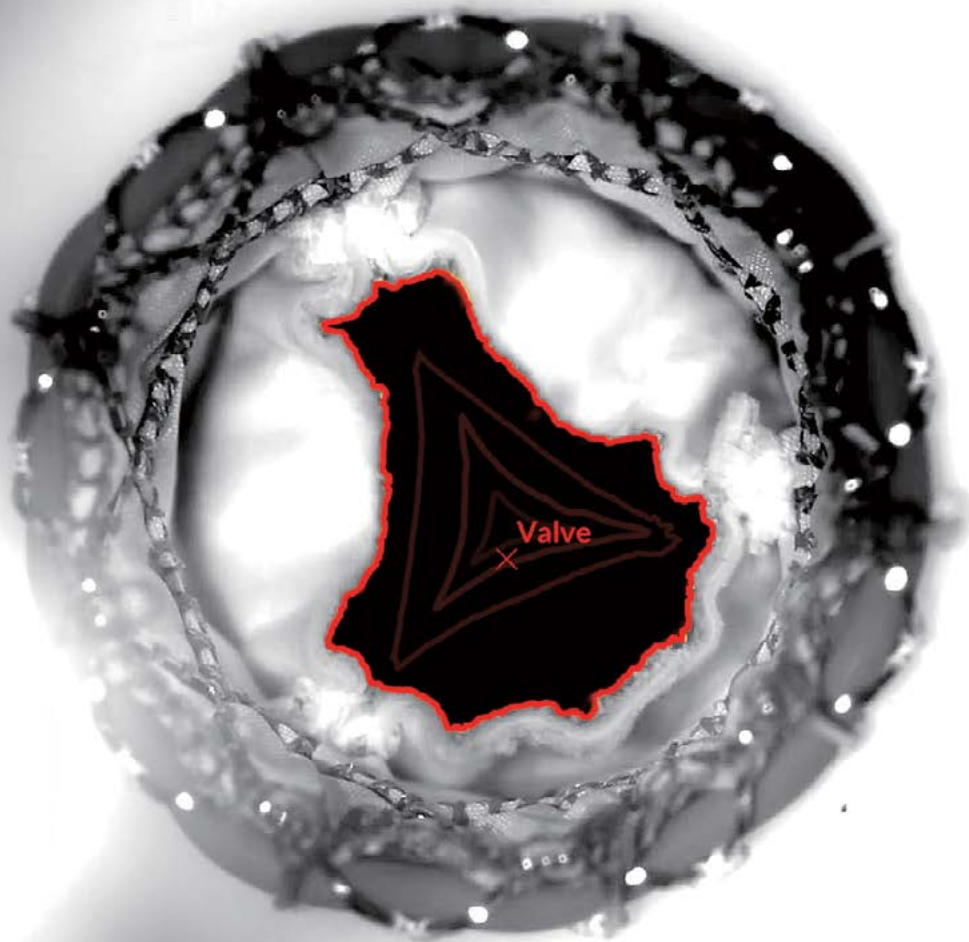

image
SYSTEMS

TEMA PRO 2D

Heart valve opening and closing analysis performed using TEMA Pro.

The outline algorithm was key to capture the contour defined by the heart valve at different stages of the opening/closing cycle.

Extreme points on this contour allowed to conclude the symmetry of the behaviour and to perform frequency analysis.

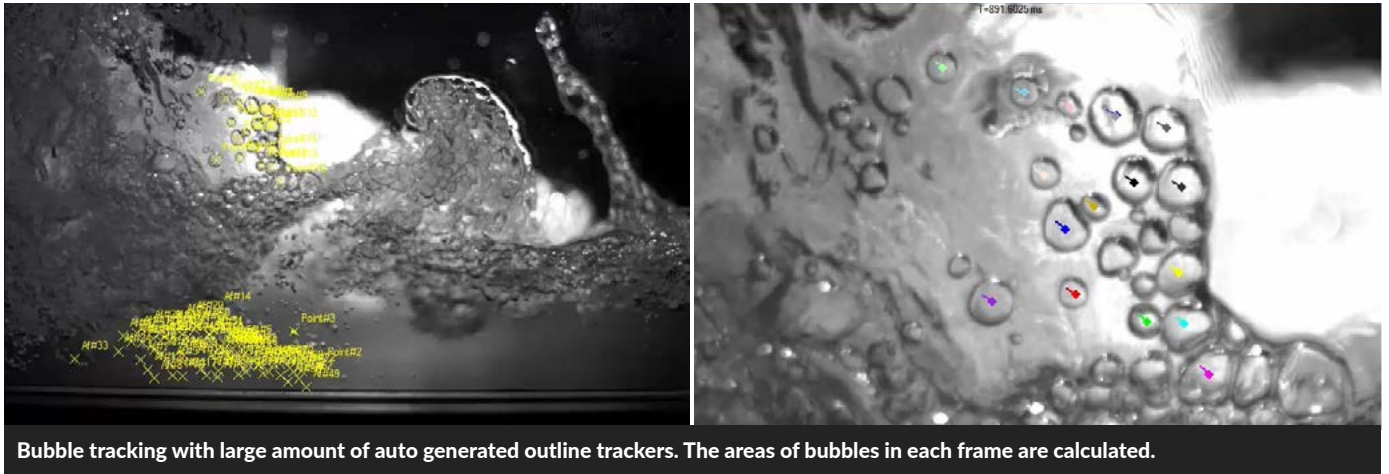

2D tracking is the basic functionality of TEMA. Tracking a marker or an object in the image sequence using any algorithm from the available library will produce 2D pixel coordinates. Those 2D coordinates can then be used to calculate velocity, acceleration, distances and angles. They will also serve for basis when dealing with 3D or 6DoF calculations.

A wide variety of time synchronized diagrams and tables allow to display tracked data versus time, per frame or even in the frequency domain.



Dynamic Coordinate System

The user can define his own coordinate system using points tracked on the image. This coordinate system can be static as well as dynamic.

In this case, the position and orientation of the coordinate system is recalculated at every frame allowing to compensate for vibration of the camera in 2D or analyze a relative movement between two objects.

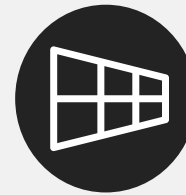

Perspective Correction (2.5D)

In case the camera is not perpendicular to the motion plane, the perspective bias will impact the quality of the end result.

The TEMA software offers several methods to calculate the azimuth and elevation angles of the camera to the motion plane and compensate for this non perpendicularity.



Multiple-Parallel Planes

In case the points are at different depths in the image, but still moving parallel to the same motion plane, TEMA can compensate by entering the known depth for the points, reducing errors resulting from depth scaling issues

Perspective Correction (2.5D) can be used in addition to this function.



Exportable 2D Data

Position, velocity, acceleration, distance and angle data (raw or filtered) can be exported in any coordinate system (default or user defined) as a function of time or per frame in various formats.

Camera views, image diagrams or combination of diagrams can be exported as animated sequences with title slates, skips and text notes for easy reporting in classic image/video formats.

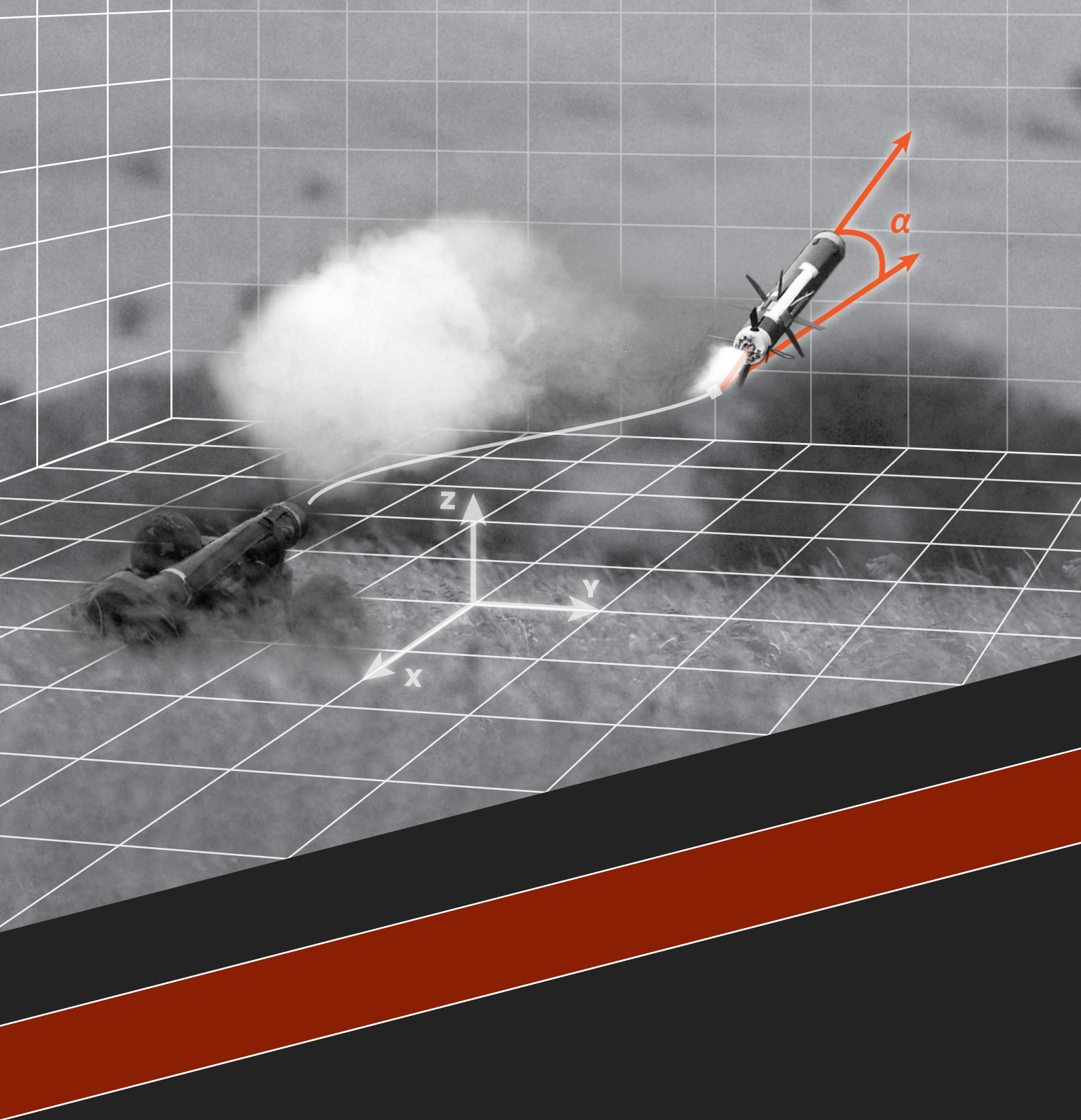
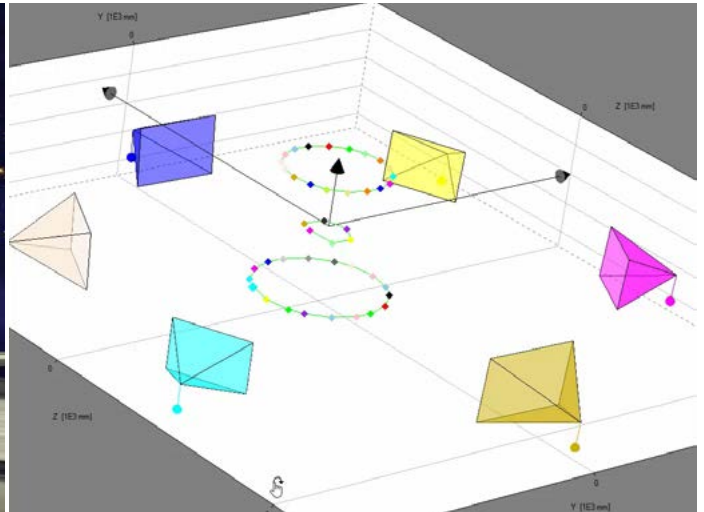

image
S Y S T E M S

TEMA PRO 3D

3D tracking of the firing of a portable missile launcher represents an advanced application. Trajectories and angles of missile are key data to assess the quality of ejection and ignition.

TEMA Pro 3D contains various algorithms to overcome complicated situations with up to 0.01 pixel accuracy. While dynamic camera orientation allows the user to correct for the vibrations of the camera during launching, a dynamic 3D coordinate system allows to create a reference frame attached to the projectile.



Satellite separation test using TEMA 3D analysis. Multiple camera views are supported for 360° tracking and angle measurements.

As long as two cameras or more are oriented in the same 3D coordinate system, any target visible in at least two camera views will have its position calculated in 3D.

TEMA takes the tracked pixel coordinates from each camera, computes the direction from each camera to the target, and triangulates a 3D-position,

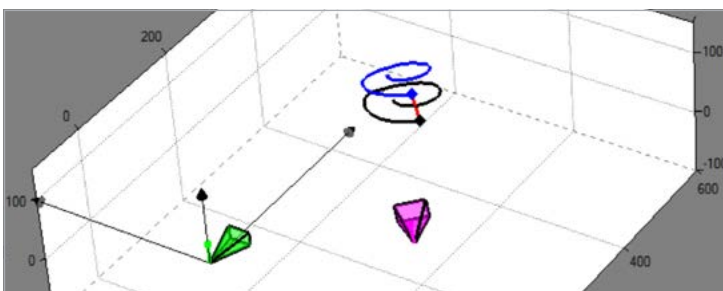
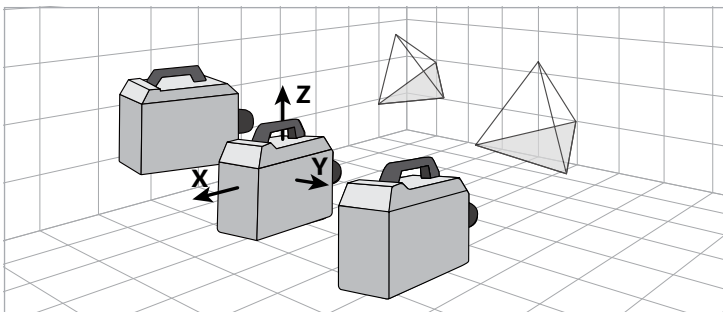
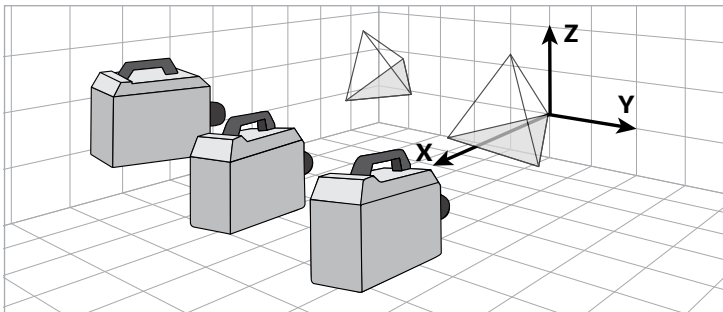

Exportable 3D Data

- Distance ● Displacement ● Velocity ● Acceleration ● Angle ● Angular speed ... regarding default/customized 3D coordinate, can be exported as time tables, point tables, (multi-axis) diagrams, 3D diagrams with raw or filtered trajectories.

Static / Dynamic Camera Orientation

- By default, 3D coordinate system is extracted from the survey file (can be edited using 3D tracked points).
- Higher accuracy with well surveyed references;
- Capable of compensating for movement of the cameras or calculate trajectories of objects relative to each other.

Relative Camera Orientation

- Default 3D coordinate system attached to the primary camera (can be edited using 3D tracked points);
- For more than two camera views, they should be calculated in pairs;
- Higher flexibility easily identifiable points;
- Suitable for quick tests or tests without well surveyed references.

3D Wand (Optional)

- Fastest and most automated
- Calibrate all cameras (≥ 2) simultaneously with:
 - ✓ Lens Distortion
 - ✓ Camera Orientation
- Generate accuracy report

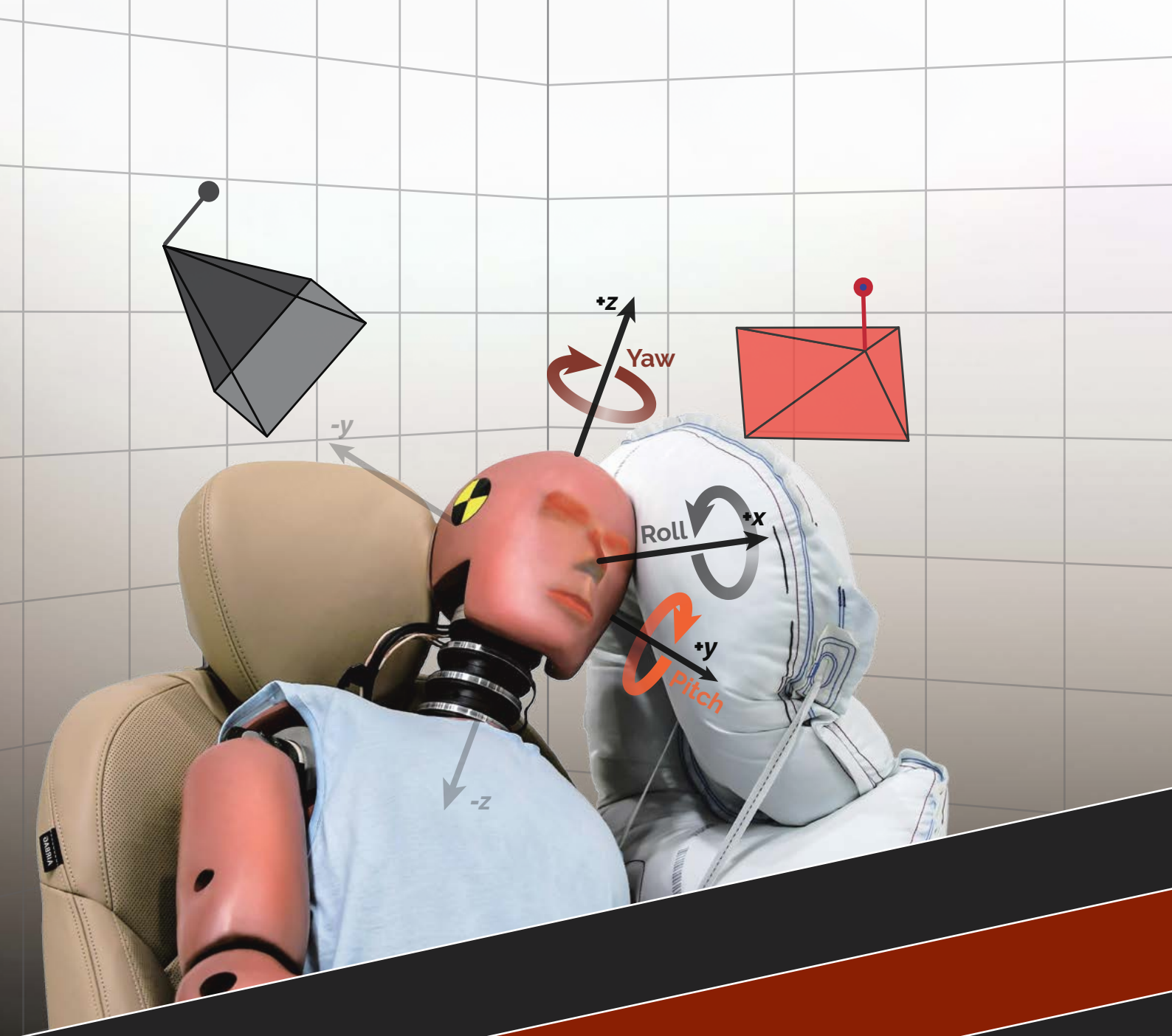

TEMA PRO 6DOF / 6D ONBOARD

For pedestrian impacts, crash tests or any application where the behaviour of a rigid body object must be analyzed, TEMA Pro 6DoF or 6D Onboard is the most suitable solutions on the market.

The analysis can be combined with the import of 3D models and CAD drawings for even more realistic representations in diagrams.

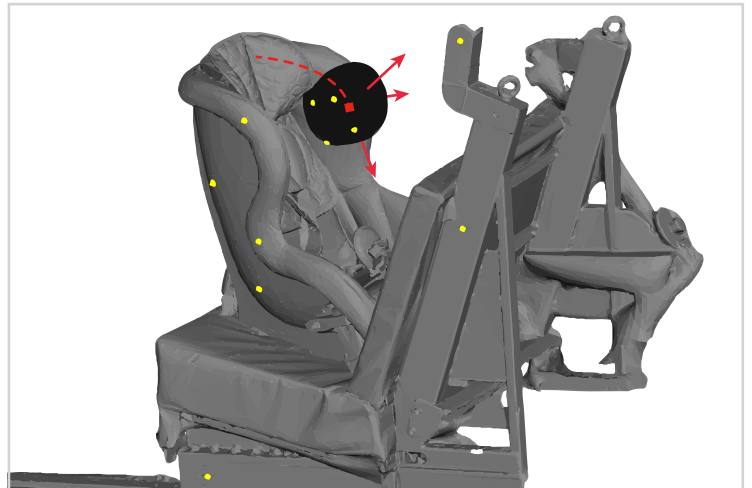
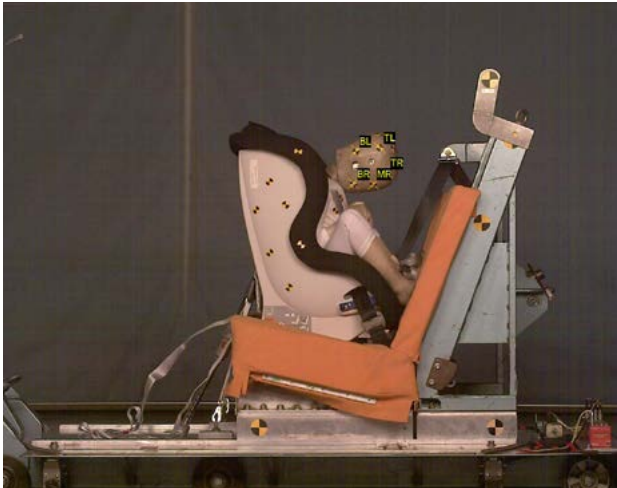

The orientation and 3D movement of the surveyed dummy head is measured by TEMA Pro 6DoF from a single camera view.

Tracking in 6 degrees of freedom (6DoF) is an optional feature of TEMA that computes the position (x, y and z) and 3D orientation (roll, pitch and yaw) of a rigid tracked object.

For each object, operator must define target models containing well-defined points with 3D coordinates in the objects' own coordinate system. The targets must be rigid structures where individual points are not moving relative to each other, typically a store, an aircraft, etc.

TEMA Pro 6DoF calculation is not only for the origin of coordinate system attached to rigid body, but also 3D positions for other points of the model.



- Unlimited number of trackable points;
- Single camera 6DoF solution for all users;
- 6D Onboard allows to combine several camera views for 6DoF analysis. Relative 6DoF analysis between two rigid objects can be performed allowing to dynamically compensate for vibrations of the camera.
- A minimum of 4 points (more recommended) and spread out over a volume or area on the rigid object must be tracked on each frame of the camera view for 6DoF analysis. Those 4 points can be shared between several camera views in the case of 6D Onboard.



Specifying the Coordinate system used for the TEMA 6DoF analysis can be done in multiple ways to suit a variety of applications:

- Target System at t_0
6DoF analysis of the object of interest relative to its orientation at $t=0$
- Camera System
6DoF analysis of the object of interest based on the coordinate system attached to the camera
- External System (6D Onboard)
Relative 6D, removing onboard camera vibrations and movements using a rigid body of reference.



- 0.01 pixel tracking accuracy;
- Onboard 6DoF with multi cameras achieves much higher accuracy by over-determination of the points during crash tests;



- 3D meshes and textures can be easily imported and aligned with the images in the camera views using trackable points to maintain accurate 6DoF tracking in the case of complex objects.
- The results can be visualized in various tables, diagrams & image export formats.



image
SYSTEMS

TEMA PRO AIRBAG

Combining outline algorithms in TEMA Pro and backward tracking, airbag testing almost becomes a formality.

Velocity and acceleration of the deployment, positions of extreme points of the outline, area, rotational volume, angle of deployment, overlay of sequences are some of the analyses that can be carried out using TEMA Pro in 2D. With at least 4 cameras and the airbag volume module (optional), volume analysis and 3D hull representing can be implemented.

AIRBAG AREA

Using background suppression and backward tracking, the outline of the airbag can be tracked accurately throughout the deployment.

The area covered by the detected contour as well as the position/velocity/acceleration of the extreme points from the outline can be displayed versus time to ensure that the cushion behaves as expected by Automotive engineers.

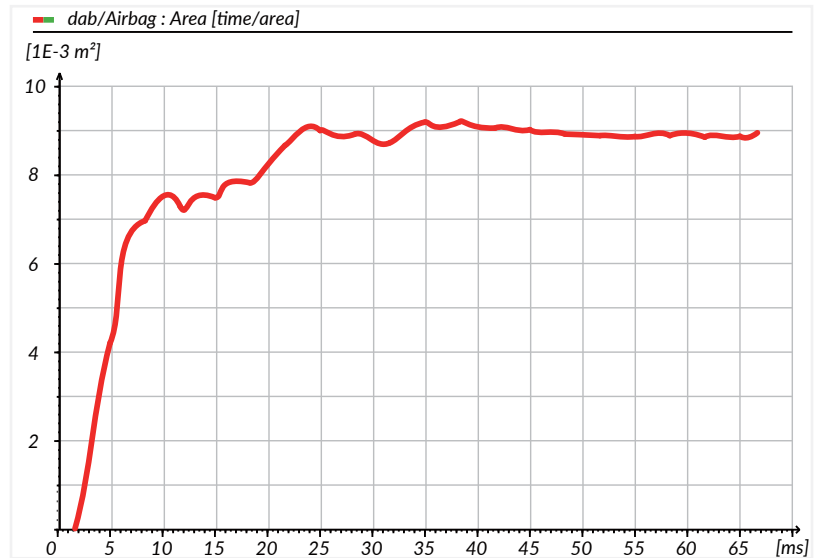
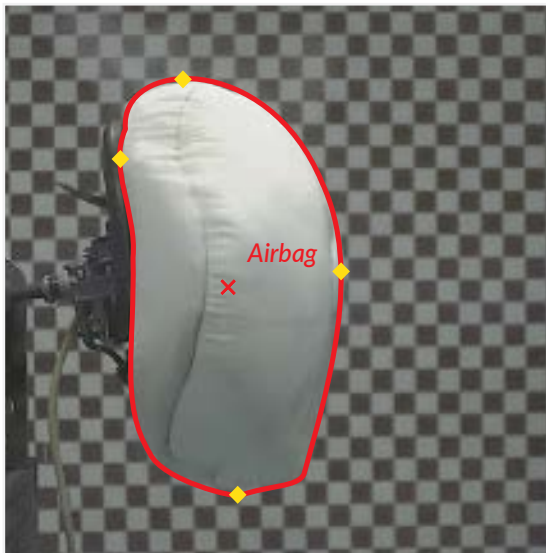

AIRBAG VOLUME

Using the airbag volume and 3D modules (optional) in TEMA Pro, it is possible to calculate the volume of an airbag during deployment by combining at least 4 cameras. The cameras need to be placed on strategic positions to cover possible complex variations of shape of the airbag hence the high number of recommended cameras.

The outline of the airbag is then analyzed in each camera view and the TEMA software computes a 3D volume based on the intersection of polygons. The behaviour of the airbag can be represented by a 3D hull in a 3D diagram and this 3D object can be exported as .obj or .stl for the selected frame to be compared with simulation results.

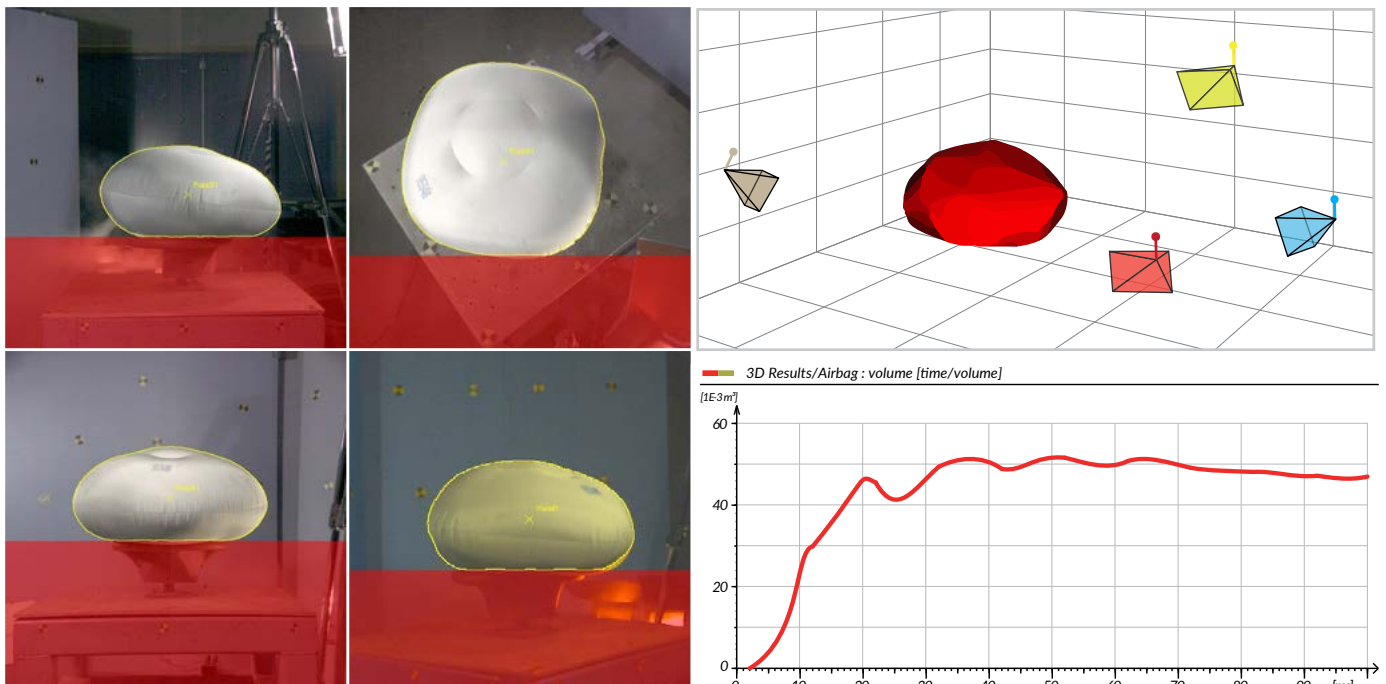

Concrete / Point #1 : DIC

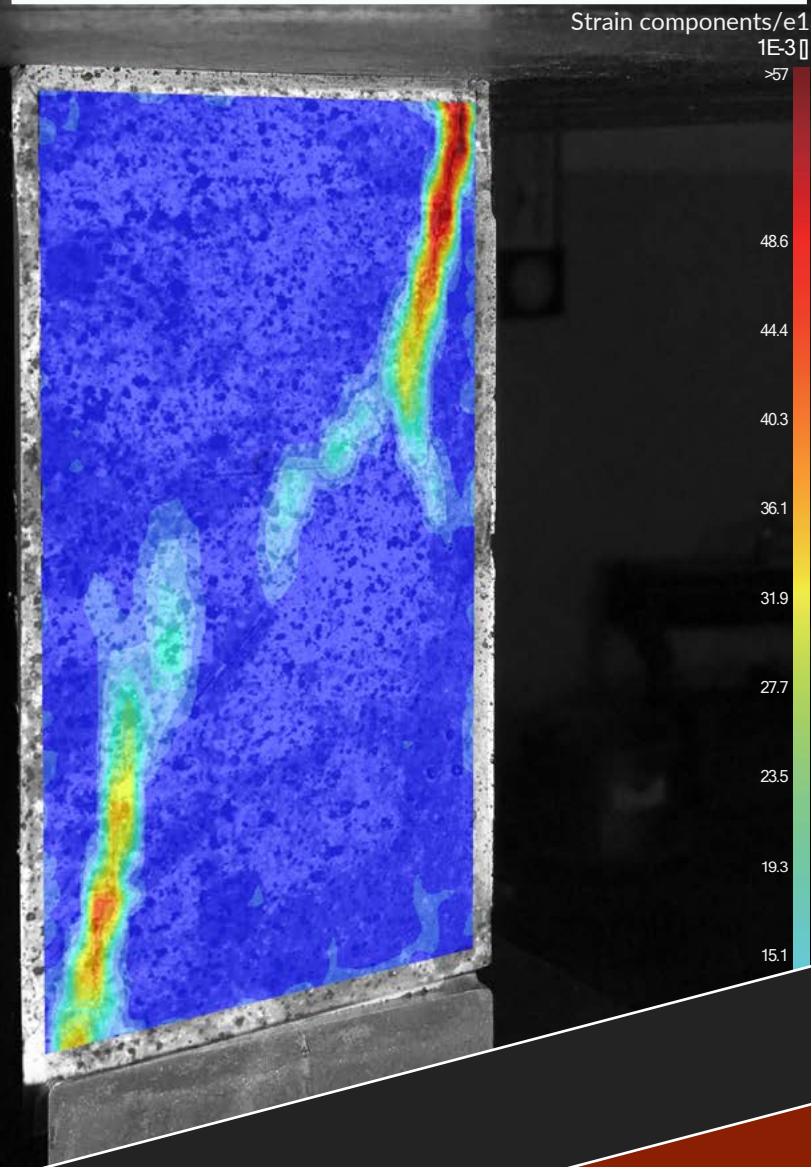

image
S Y S T E M S

TEMA PRO DIC

Digital Image Correlation (DIC) allows surface deformation and strain analyses in full field by tracking the movement and deformation of a speckle pattern painted on the object of interest. A set of specific DIC tools is part of this package such as inspection lines, virtual extensometers and local points of interest to provide even more statistics on the surface.

Ideal for fatigue testing, material characterization or to understand the behaviour of a structure under constrains, this non contact technique can be combined with strain gauges for even further accuracy.

As a good experimental setup is the corner stone of a successful 2D & stereo DIC analysis, Image Systems has gathered the feedback, advice and requirements of mechanical engineers as well as industrials from the automotive, military and aeronautical to develop two accurate and high quality turnkey systems.



DIC EMBEDDED SYSTEM

- Robust design, easy setup
- Fixed stereo FOV with high resolution
- Low-medium frame rate available
- Calibrated lenses, low distortion
- Continuous lighting
- Compatible with DAQ systems
- Real-time (<20 fps) measurement
- Ideal for tensile and compression testing



DIC ELITE SYSTEM

- Flexible design, smart alignment tool ensures easy setup and quality results
- Customized positioning with various resolutions
- Industrial, high-speed (streaming) cameras supported
- Interchangeable lenses, flexible FOV
- Customizable lighting
- Compatible with DAQ systems
- Real-time (<20 fps) measurement

BLAST ANALYSIS

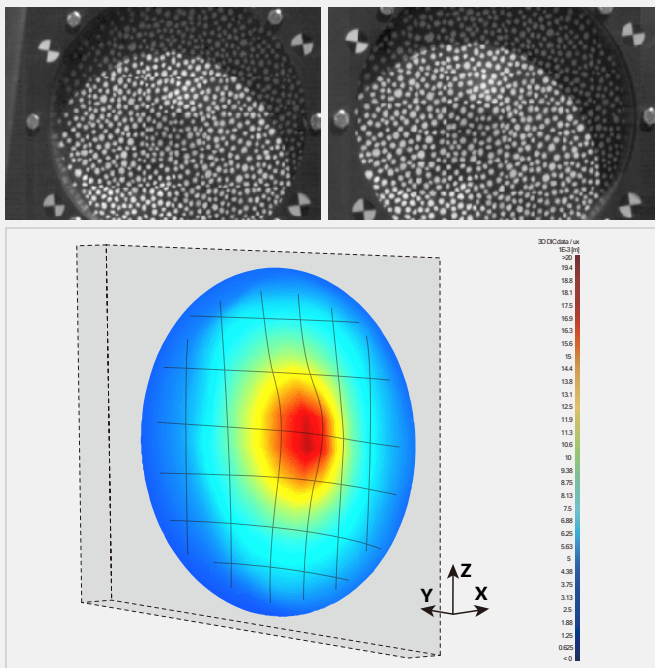

Dynamic stereo deformation of a metallic plate under the action of a blast shockwave recorded by high-speed cameras can be analyzed easily using TEMA Pro and 3D module.

3D displacement as well as the main/minor components of the strain can be displayed in 3D diagrams with colour maps or overlaid on the camera views in order to get a full understanding of the blast behaviour.

Positioning points of interest on the surface allows the user to measure the displacement maximum locally as well as the frequency of the plate vibrating with the shockwave.

FABRIC OR SKIN DEFORMATION ANALYSIS

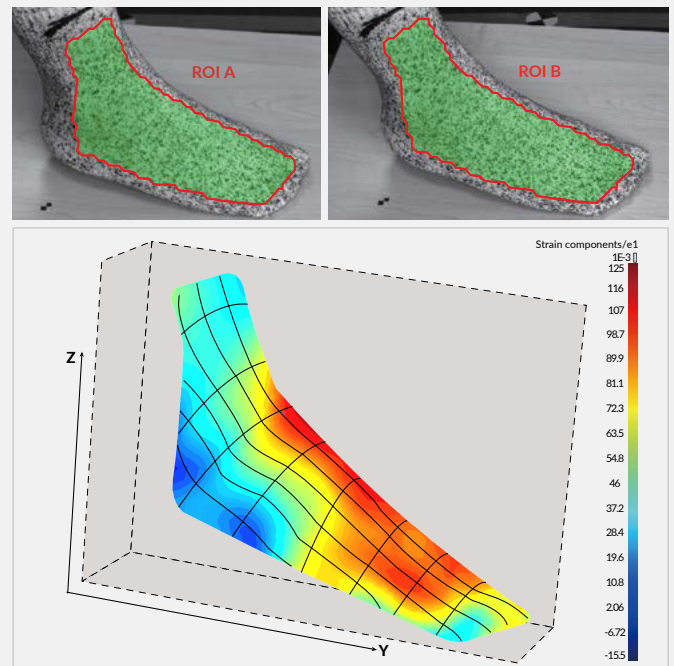

Under the influence of body movements, shocks or impacts, the skin (or the fabric on the skin) can deform in an elastic way.

By analyzing this deformation using DIC algorithm in TEMA Pro, it is possible to see and quantify what kind of strain the body is subjected to during those scenarios.

This is particularly useful in biomedical applications, to identify asymmetries in the body, which could lead to back pain. It could also be part of the design future sporting equipment, such as shoes, where they should help the body sustain the repeated force from the ground.

It can also be used in the design of ballistic protection for the deformation of bulletproof vests, impacted by projectiles.

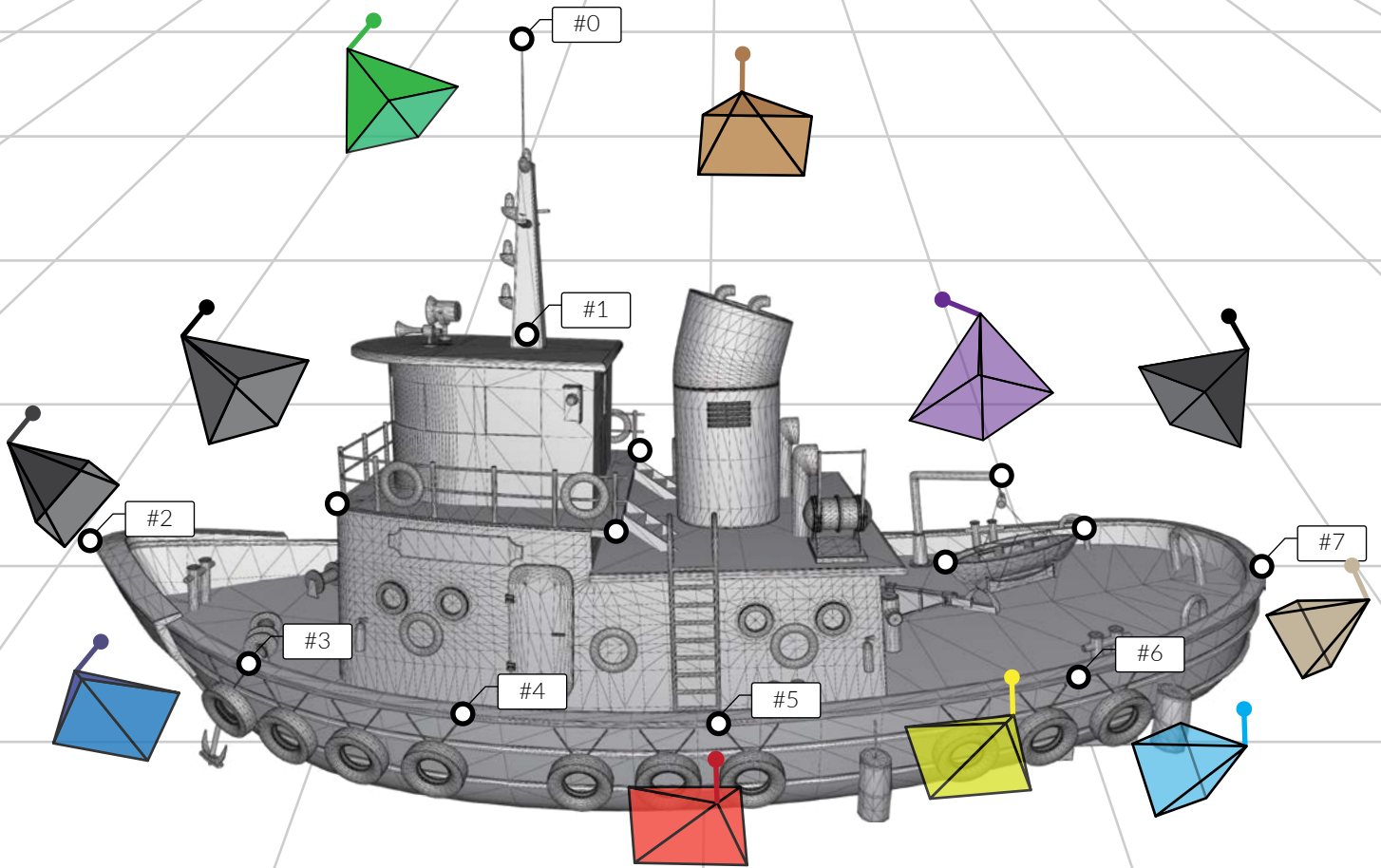

Image
SYSTEMS

TEMA STATIC 3D

6DoF study for an object floating in artificial waves is a classic application in Marine Engineering. To be able to analyze the object with TEMA 6DoF, a 3D-target containing surveyed points are needed.

TEMA Static 3D is a fast survey toolkit to capture multiple images of the boat, and calculate the 3D positions of surveyed points based on Photogrammetry.

Static 3D is a powerful software tool capable of generating 3D models and measurement data - from static objects and environments - using still imagery. Measurement points can be manually selected in the images, or automatically identified using markers.

Manually selecting points in the images allows the operator to retroactively derive measurement data from the images, even if markers were not placed.



Using the calibrated camera from the system, the operator captures a series of images of a target object or environment to be measured.

At least six common points (more recommended) should be visible by pair of images. The points could either be quadrant markers, hand drawn markers, or shapes/contours of the object. Finally, one physical distance (acting as scale) between two points must be known to complete the process.

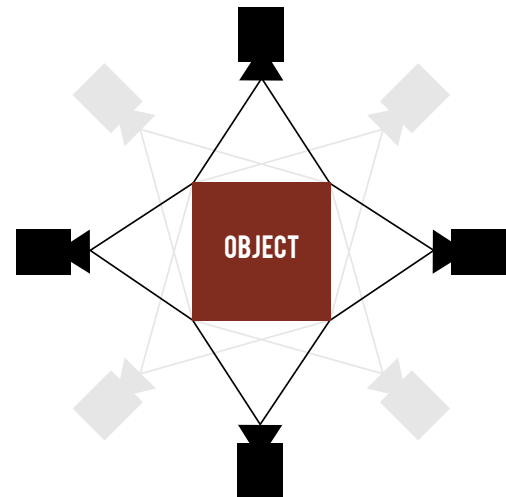

Key Features

- High precision 3D modelling;
- Flexible for large scale object measurements;
- Cost-effective with DSLR camera & prime Lens;
- Retroactive measurements;
- Various export formats (DDXF, ASCII, CSV files, CAD software export, etc.)

The software wizard will then generate the X, Y, Z data of markers and/or manually selected points and create a 3D target model.

The data of the Target Model can be visualized in a point table (X, Y and Z) as well as in a 3D diagram for verification purposes.



Point	Status	Views	x (cm)	y (cm)	z (cm)	parallax (cm)	From	To	Distance (cm)
1	Adjusted	4	17,267	-3,285	-3,459	0,00213	24	25	9,462
2	Adjusted	5	18,382	-0,017	-3,820	0,00392	32	33	9,727
3	Adjusted	6	17,352	3,354	-3,432	0,00792			
4	Adjusted	5	13,689	5,317	-2,088	0,00159			
5	Adjusted	7	13,287	2,834	-1,706	0,00327			
6	Adjusted	6	13,829	0,038	-1,516	0,00339			
7	Adjusted	6	13,308	-2,798	-1,816	0,00197			
8	Adjusted	5	13,652	-5,478	-2,285	0,00182			
9	Adjusted	6	11,474	-4,144	-1,681	0,00262			
10	Adjusted	8	7,372	-3,228	-0,187	0,00442			
11	Adjusted	9	7,429	2,978	-0,108	0,00383			
12	Adjusted	7	11,380	3,974	-1,499	0,00368			
13	Adjusted	10	0,000	0,000	0,000	0,00346			
14	Adjusted	7	1,341	3,108	0,111	0,00463			
15	Adjusted	6	-2,055	-6,238	-1,201	0,00646			
16	Adjusted	7	-0,943	6,105	-0,961	0,00395			

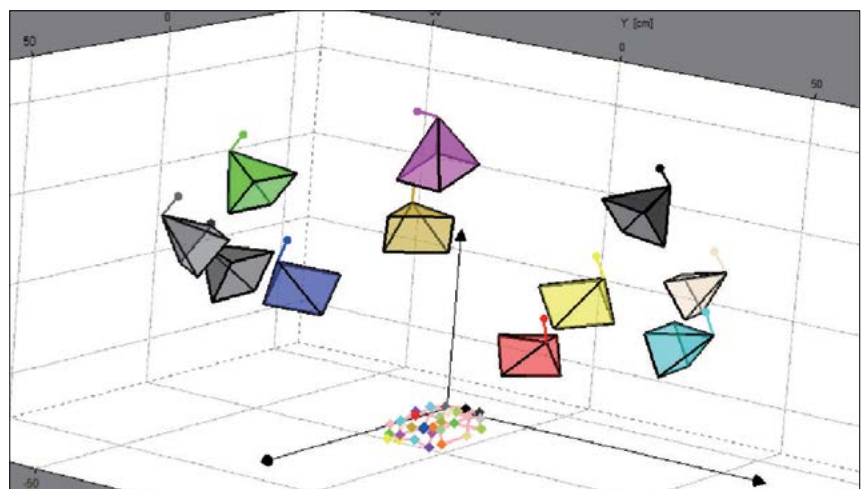



image
SYSTEMS

TEMA MODEL 3D

3D modeling is an important factor in increasing the accuracy during 3D or 6DoF motion analysis of rigid bodies, especially when the points of interest are masked or difficult to track.

The shortest 3D distance between several 3D models or one 3D model and a reference point can be computed versus time, allowing to find contacts between rigid body objects even with no direct visibility from the camera.



Model 3D is an optional module that allows the integration of dense and precise 3D targets of rigid objects and environments created with 3D scanners or CAD into TEMA 3D diagrams.

The ability to use dense 3D targets with surface texture dramatically increases the understanding of any 3D or 6DOF analysis, but also adds more data. The 3D Model feature set lets you retrieve the 3D position of any point in a dense 3D target, real tracked points as well as virtual ones that were never tracked in the image sequences.

Various hand held 3D scanners are compatible to be integrated into TEMA to build a turn-key solution.

Optional Features:

Technical Specifications	Space Spider	Eva	Leo
3D point accuracy, up to (mm)	0.05	0.1	0.1
3D resolution, up to (mm)	0.1	0.5	0.5
Working distance (m)	0.2 - 0.3	0.4 - 1	0.35 - 1.2
Volume capture zone (cm ³)	2,000	61,000	160,000
3D reconstruction, up to (fps)	7.5	16	22
Texture resolution	1.3 mp	1.3 mp	2.3 mp



Key Features

- Most flexible way to acquire 3D models from real objects during 6DoF test preparation
- Re-constructing 3D motions with meshes and textures, more visualized in 3D diagram
- Acquiring every 3D point data on the rigid bodies during motion analysis, even ones that are obscured
- Distance and angle measurements between any scanned surfaces or points
- Most accurate solution on the market

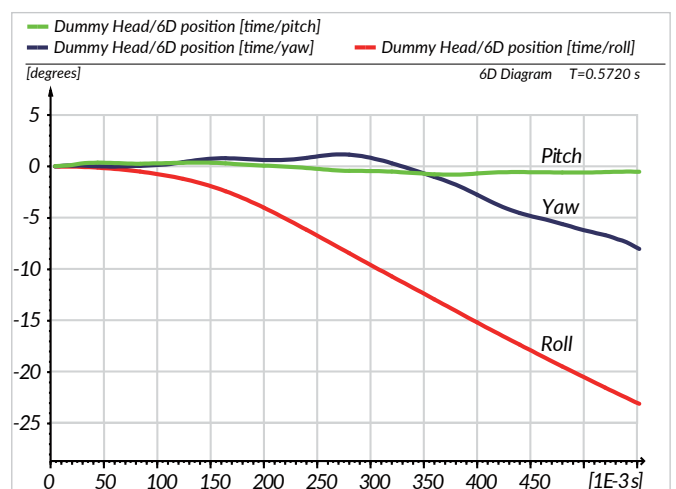

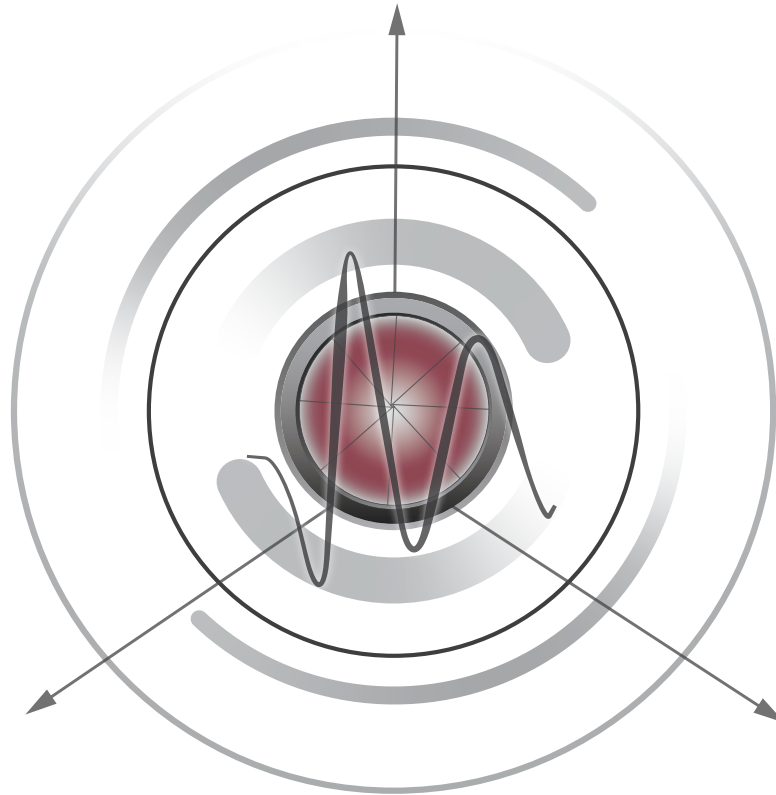

ADVANCED MOTION ANALYSIS

image TEMA PRO

Contact

Image Systems Nordic AB

Snickaregatan 40, 582 26

Linköping, Sweden

sales@imagesystems.se

Note

For TEMA T2020
and more recent versions